

MODEL FH-11

Universal Hardness Testing Machine

Universal



HR



HV



HB



FH-11 Series with
six-position
motorized turret



Features and benefits

- Rockwell, Superficial Rockwell, Vickers, Knoop, Brinell, Ball indentation, HVT and HBT scales.
- Superior range of test loads/force application ranging from 1kgf (2.2lbf) to 3000kgf (6614lbf) over three models.
- Fixed workpiece position (no spindle).
- Descending test head with automatic workpiece detection.
- Free definable, manual or motorized six-position turret for objectives and indenters at choice.
- High definition optical system for images of 0.7-1000x magnification.
- Horizon hardness testing firmware and database file system.
- Large, adjustable 15in (381mm) industrial touchscreen.
- Automatic or manual focus, manual or fully automatic indent measurement – standard.
- LAN, WLAN, USB-2, RS232, printer and DVI connectivity – standard.
- Built-in hard drive offers nearly endless file storing – standard.
- Free definable test patterns case depth, traverse, free style, etc - optional
- Machine covers made of shock, damage and fire-resistant and recyclable materials.
- Large range of optional accessories.
- Large testpiece accommodation H=300mm (11.8in) x D=220mm (8.7in).

MODEL DETAILS

- **FH-011-0000** 1-250kgf Universal
- **FH-011-0001** 3-750kgf Universal
- **FH-011-0002** 10-3000kgf Universal
- **FH-011-0032** 1-250kgf Rockwell, Superficial Rockwell, HVT, HBT, plastic ISO 2039/1

Specifications

Universal



HR



HV



HB



FH-11 SPECIFICATIONS

Scales/test loads/force	1kgf/9.8N/2.2lbf to 250kgf/2.45kN/551lbf; 3kgf/29N/6.6lbf to 750kgf/7.35kN/1654lbf; 10kgf/98N/22lbf to 3000kgf/29kN/6614lbf
Rockwell, A- H, K-M, P, R, V	All scales (depending on model)
Superficial Rockwell, N, T, X, Y	All scales (depending on model)
Vickers HV	1kgf/9.8N to 120kgf/1176N (2.2-265lbf) (depending on model)
Knoop	1, 2kg (depending on model)
HVT	50kgf/490N, 100kgf/980.7N (110lbf, 220lbf)
Brinell	1kgf/9.8N/2.2lbf to 3000kgf/29kN/6614lbf (depending on model)
HBT	5/250 (depending on model)
Force application system	
Linear force actuator	Standard
Load cell, closed loop, force feedback system	Standard
Motorized heavy duty turret with six positions	Standard
Indenter positions	3
Objective positions	3
LED optical indent workpiece illumination	Standard
Optical measuring system	
5 megapixel high definition optical system	Standard
Auto focus	Standard
Manual focus	Standard
Fully automatic indent measuring	Standard
Manual on-screen indent measuring	Standard
Magnification ratio	0.7-1000x
Depth measurement system	
Heidenhain high resolution optical systems	Standard
Hardware and user interface	
Adjustable 15in full color industrial touchscreen	Standard
MS Windows 7 Ultimate license	Standard
Horizon FH-11 hardness testing firmware	Standard
Automatic image and file storage	Standard
Stores files images	Standard
Forms FH-11 set of customized reports	Optional
Universal motorized X-Y stage controls	Standard
Connectivity	
External digital (DVI) TFT screen output	Standard
External keyboard and mouse connections	Standard
LAN (local area network connection)	Standard
WLAN (wireless network connection)	Standard
Bi-directional RS232	Standard
Printer/USB-2 output	Standard
Built-in motorized X-Y stage driver	Standard

FH-11 SPECIFICATIONS

Hardness resolution	0.01 Rockwell, 0.1 Vickers, 1 Brinell
Objectives	Three installed for 0.7-1000x
Workpiece accommodation	Vertical capacity 300mm
Horizontal capacity	220mm/8.7in (from center-line)
Force tolerance Max.	< 1%
Force control	1-99 seconds
Light source	White power LED
Power supply	100 to 220V AC, 50/60 Hz, single phase
Weight	242kg (534lb)

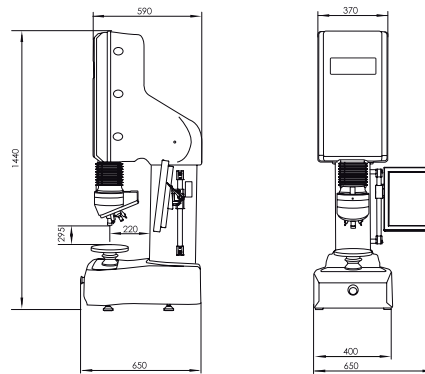

FH-11 - all measurements are in mm

STANDARD FEATURES

- Flat anvil ø80mm (3.15in)
- V-anvil ø80mm (3.15in)
- Testing table ø200mm (7.87in)
- Installation and user manual, certificate

OPTIONAL ACCESSORIES

- Certified indenters
- Certified hardness test blocks
- Large testing table 350 x 250mm/138 x 98in with T-grooves
- Extra large testing table 450 x 350mm with grooves and support
- Motorized X-Y stages (CNC), motorized rotary or tilting tables (250kg maximum capacity)
- Built-in five-axis support driver
- Certified reference blocks
- Single or multiple Jominy stage
- Automated Jominy testing